

HOWO Tipper Truck

20-30Tons Capacity and Front Hydraulic Lifting Device

User's Manual



www.howotrucks.com/

Dump Truck

OWNER'S MANUAL

Preface

Thank you for purchasing our products. For better using your HOWO 6x4 Dump Truck, get the best operating performance, we strongly suggest that before the operation process you should read this manual instructions carefully, and to manipulate the program handily.

The manual detailed describes the performance of dump truck, structure, usage, precautions and maintenance of such knowledge. While showing details of the truck, both pictures and description will together help you get better understanding of how to use truck. Before the operation, the skilled operator should carefully read the contents of the manual.

After master the truck performance characteristics, methods of operation and precautions, then could start to operate this dump truck. In order to ensure the staff turnover after the operation, and properly use of the truck. This manual book must be properly kept, shall not be lost and damage.

Contents

Chapter 1. General Description.....	5
Chapter 2, Main Technical Data	6
Chapter 3, What is Dump Truck	7
i , Dump Truck Basic Structure	7
ii , Dump Truck Working Principle.....	8
Chapter 4, How to Operate Dump Truck.....	10
i ,Dump Truck Introduction.....	10
ii ,Dump Truck Operation Guidance (Very Important).....	11
Chapter 5, Others for Attention	14
Chapter 6 Troubleshooting.....	15

Chapter 1. General Description

Our Dump Truck based on type II HOWO 6x4 LHD chassis; tipper body capacity could up to 20-30 tons. The truck uses hydraulic system and mechanical system to realize truck good self-discharging function. Trucks widely used in city, mining area, construction area, etc.

The vehicle designed to fully rely on the advantages of the original HOWO 6x4 left-hand-drive chassis, fully consider the product's convenience, reliability and features. The tipping model can be optional as rear tipping system and side tipping system, which use operation valve to control hydraulic cylinder working. The tipper body material is international standard high strength steel, all with anti-rust painting, which can effective to avoid rusting.

The HOWO 6x4 Dump Truck equipped with high quality dump body and middle hydraulic lifting cylinders, which loading capacity can be 10Tons. The dump trucks widely used together with excavator trucks, loading trucks and belt conveyor machine. Therefore, the dump truck is an ideal Construction Truck mainly for heavy duty goods loading & transportation.



(Preview for your HOWO 20tons Dump Truck)

Chapter 2, Main Technical Data

Basic parameter:

Items		6x4 HOWO Dump Truck
S I Z E	Outer Dimension (L×W×H) (mm)	8800x2500x3400
	Wheelbase (mm)	4625+1350
Kerb Weight (kg)		12800
G E A R	Gearbox brand	HW19710
	Model	10-shift gearbox
	Type	Manual
Cab capacity (includes driver)		2
E N G I N	Model	WEICHAI WP10.380E22
	Type	Six cylinder inline, water-cool, turbocharged Inter-cooling, diesel
	Rating Power (kW/HP)	280/380
	Emission Standard	Euro 2

Note: 1. The vehicle height includes tipper body front fence.

2. We keep the right to revise the parameters on the list above.

Dump System basic parameter list

Items		Parameter	
Control System		Hydraulic control system	
Hydraulic Lifting		Front heavy lifting device	
Dump Body	Capacity (Ton)	20-30	
	Material	High Strength Carbon Steel	
	Painting	Internal	With anti-rust painting
		External	Black painting
	Dimension	Length (mm)	5600
		Width (mm)	2300
Height (mm)		1500	

Chapter 3, What is Dump Truck

i , Dump Truck Basic Structure

Our dump truck also named tipper truck, self-discharging truck. This based on famous HOWO brand truck chassis, refitted with special upper structure. And the components consist of Middle Hydraulic Lifting Device, Dump Body, Auxiliary Frame and Spare Parts. Sample technical drawing with component as following:

Middle Hydraulic Lifting Device: *This device including gear pump, lifting valve, hydraulic oil pipeline system, lifting device, position-limit mechanism.*

Dump Body: *Which material is high strength carbon steel, including front plate, side plate, bottom plate, rear plate, and rear door switching mechanism.*

Auxiliary Frame: *Which material is high strength carbon steel, including longitudinal frame, transverse frame, lifting shaft, and welding place to main frame.*

Spare Parts: *This including safety jackstay, position-limit device and balance support.*

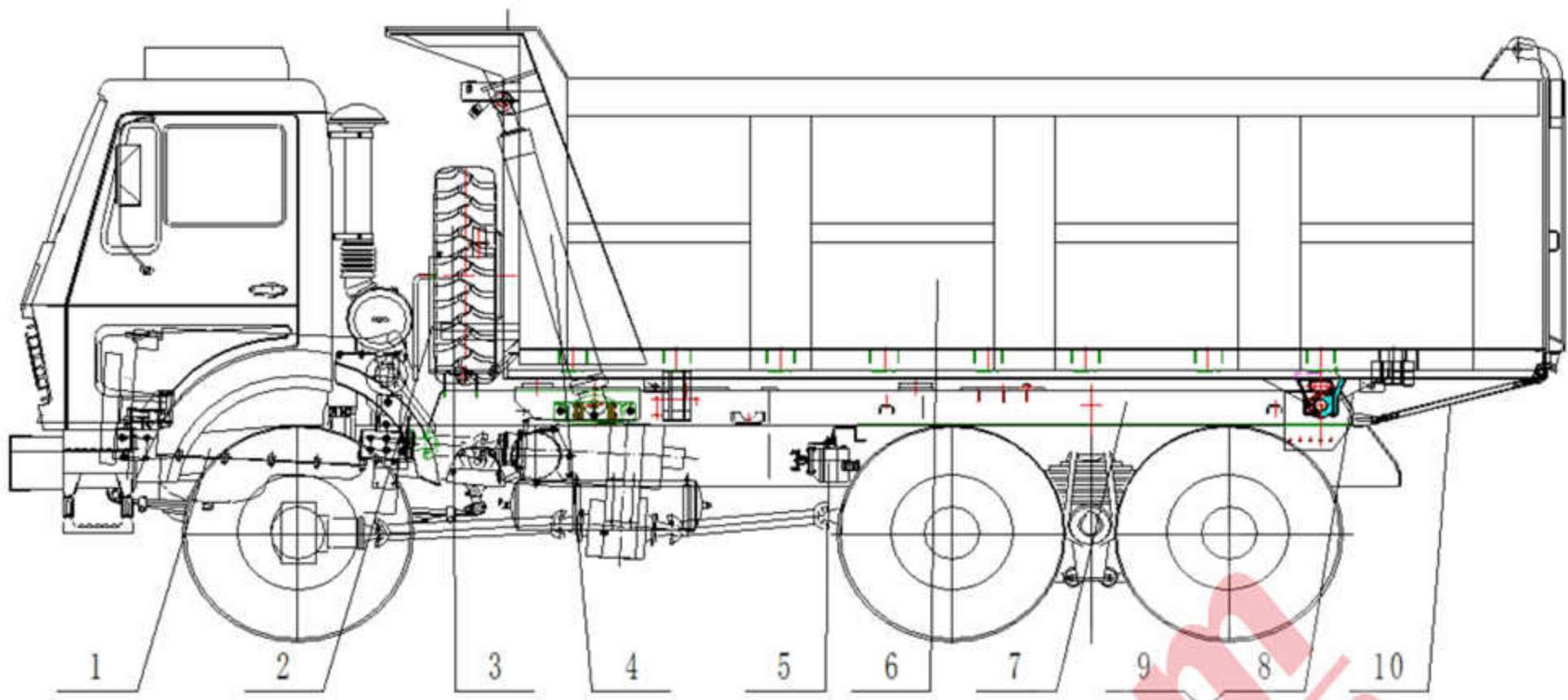

Sample Drawing for Dump Truck (6x4 model)

- 1、 HOWO Chassis 2、 Hydraulic Oil System 3、 Spare Tire Device 4、 Hydraulic Lifting Device
 5、 Gear Pump Assembly 6、 Dump Body Assembly 7、 Auxiliary Frame Assembly 8、 Mudguard Assembly
 9、 Rear Lamp Assembly 10、 Body Lock Device (Rear Door Switching Device)

ii, Dump Truck Working Principle

As for hydraulic lifting system, which including control valve, PTO, gear pump, transmission shaft, hydraulic oil cylinder, hydraulic oil tank, oil pipeline, position-limit valve. etc.

The PTO (Power Take Off) gets power from Truck Engine, then transit power to Gear Pump through transmission shaft, the Gear Pump start working, Control Valve can control the hydraulic cylinder working, which can make dump body up and down working, then realize the self-discharging function.

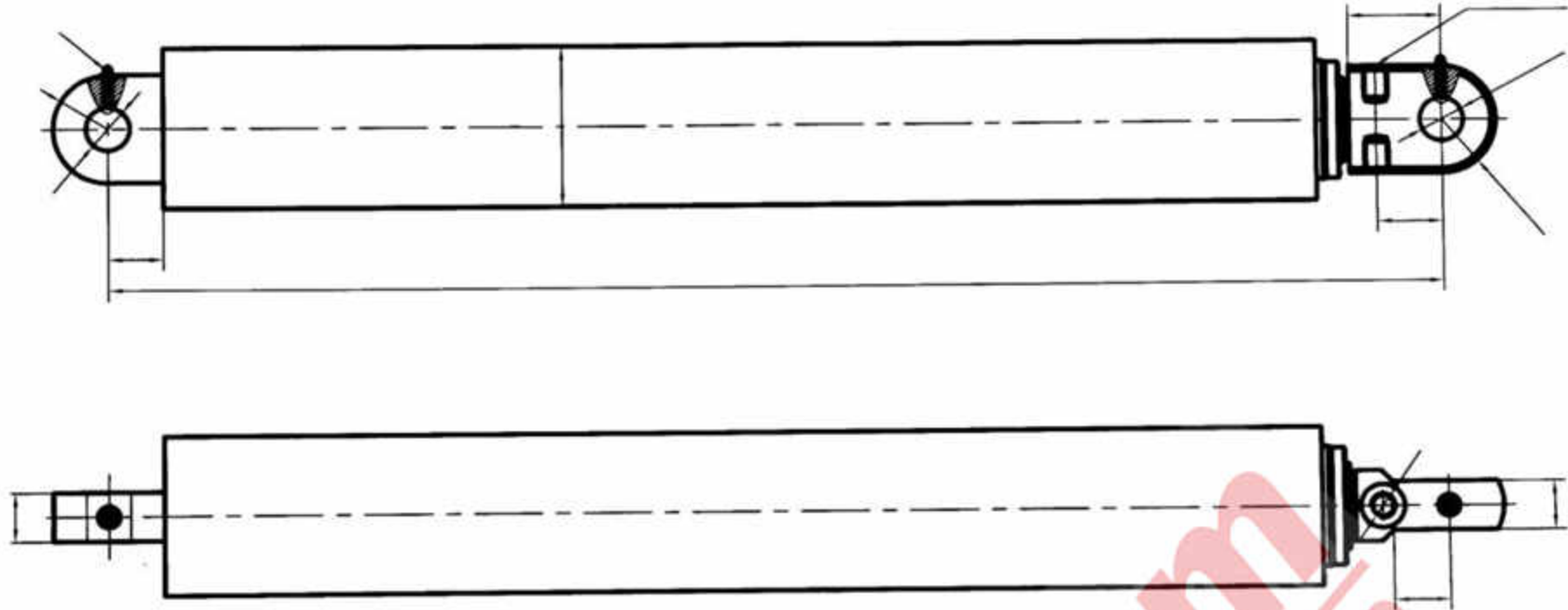

Hydraulic cylinder

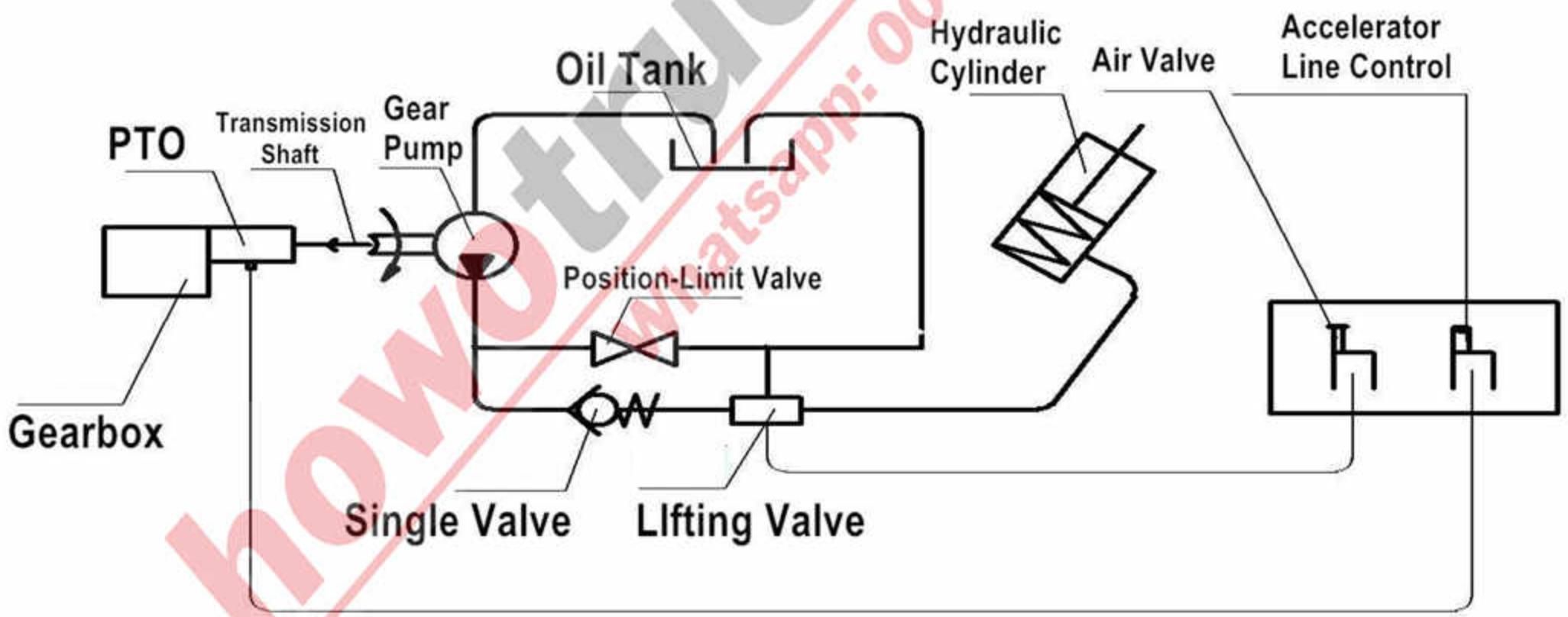

Hydraulic Lifting System working diagram

Chapter 4, How to Operate Dump Truck

i ,Dump Truck Introduction

Kindly refer to Chapter 3 and details for dump trucks showing as below.

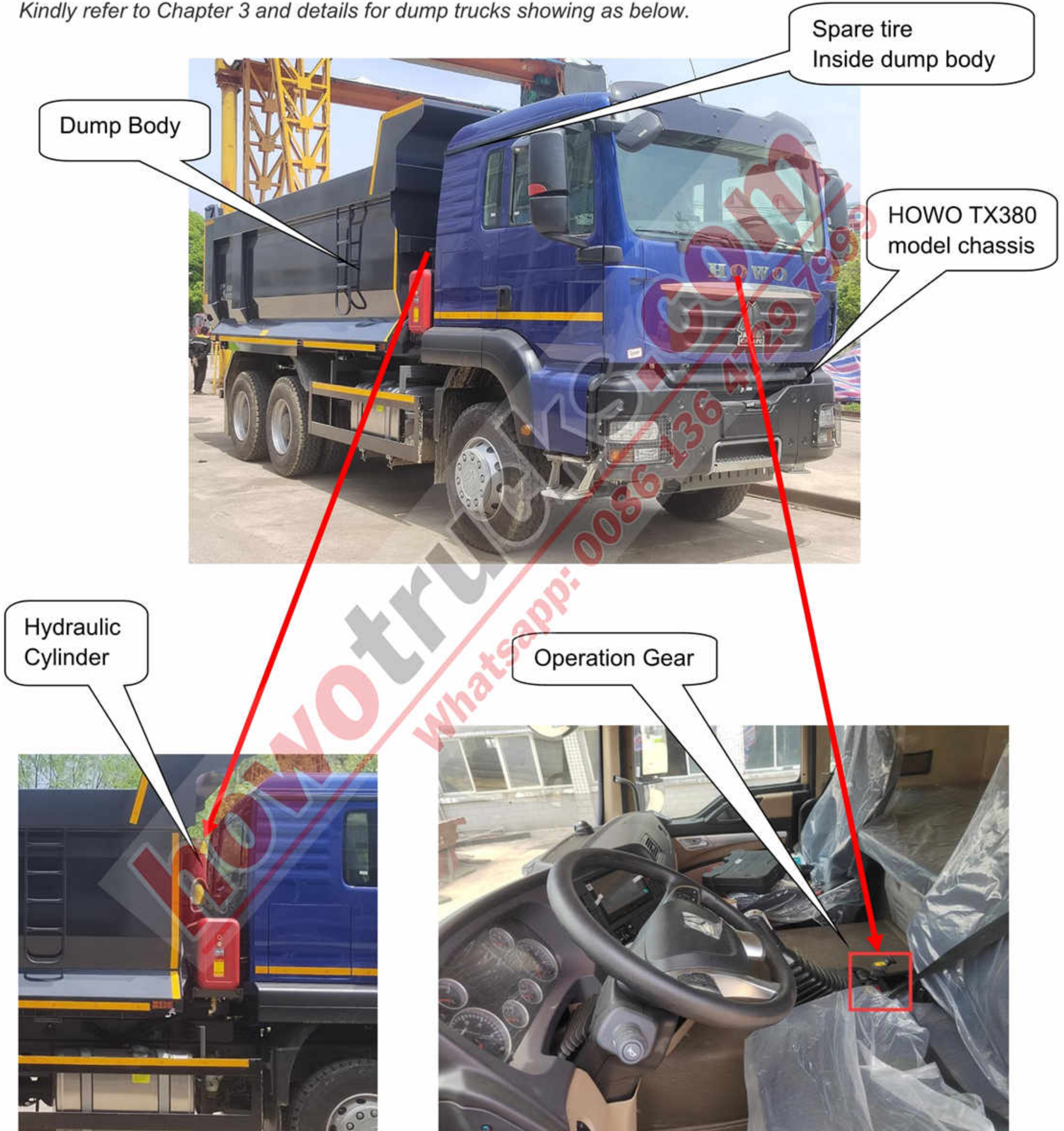



Rear Position:
 Valve control the hydraulic cylinder extend out to make dump body lifting up for discharge work

Front Position:
 Valve control the hydraulic cylinder retract back to make dump body falling down for driving position

UP POSITION: Dump body Lifting Up
 DOWN POSITION: Dump body Falling Down

ii, Dump Truck Operation Guidance (Very Important)

1. **The Preparation for Operation:** Carefully checking the operation environment, make sure no person stands around the truck, also do not forget pull the Parking Brake before any operation.
2. **PTO Operation:** Before operating the dump system, please make sure the PTO is working. Detail operation process should as follow, firstly start the truck engine and depress the clutch panel, secondly pull out the PTO switch, thirdly slowly loosen the clutch panel, then the oil pump start working.

NOTE: Please push in the Accelerator Switch Button while driving the truck!
 Please does not operating the dump system while driving the truck!

3. **Dump Truck Operation:** Carefully follow below guidance to operate your dump truck.

Factory: No 9, Jiliang Avenue, Economic Zone, Suizhou Hubei, China
Tel: +86 136 4729 9000 Official Web: www.howotrucks.com Email: info@howotrucks.com

➤ **Start Up:**

Start truck engine, keep the vehicle stops (neutral gear), and press the Clutch Plate and same time PULL OUT Accelerator Switch button, then PTO start working.

➤ **Lifting:**

Operate the Control Device in Cabin to UP POSITION, the dump body start lifting up; press the accelerator plate can make lifting process faster.

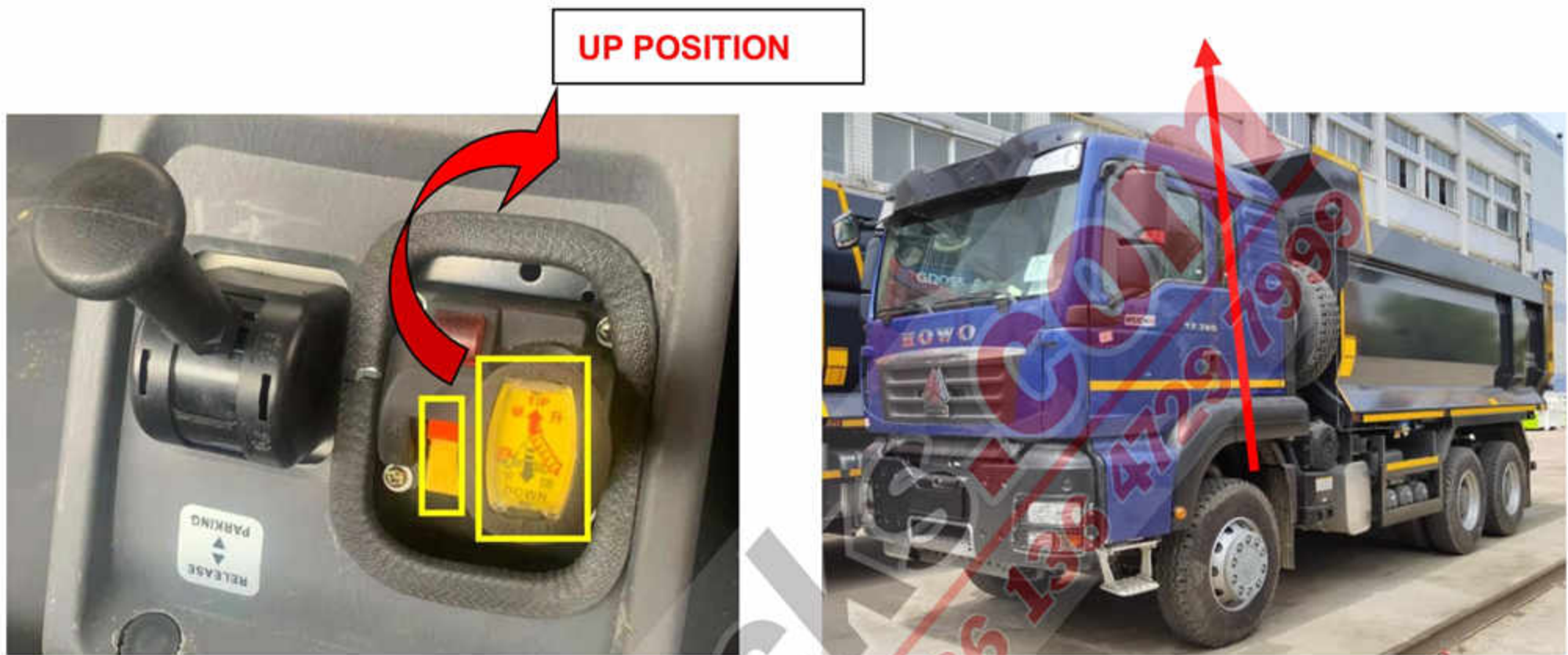

Operate the Control Device

Dump body lifting up

➤ **Falling:**

Operate the Control Device in Cabin to FRONT POSITION, the dump body start falling down, press the accelerator plate can make falling process faster.



Operate the Control Device

Dump body falling down



Mechanical rear door lock,
self-open/self-close during
dump body lifting/falling
process

howotrucks.com
whatsapp: 0086 136 4729 9000

Chapter 5, Others for Attention

After carefully reading the above information, you must be well known how to use the HOWO 6x4 Dump Truck; below show some parts you need to pay attention while using the truck.

- 1. The loaded materials should be distributed in the body, strictly forbidden overloading.*
- 2. Keep nobody stand around when operating the dump truck.*
- 3. Strictly forbidden the PTO on Working Position during the truck driving.*
- 4. Strictly forbidden the Control Device UP POSITION during the truck driving.*
- 5. Please keeps the dump truck in flat road during discharging working, strictly forbidden discharging working in a transverse slope.*
- 6. During the whole loading and unloading process, the operator should not leave the Control Device, in case of there is an emergency.*
- 7. When truck stopped and ready for lifting work, operator should start the truck engine firstly, and make the engine idle for 3~5 minutes, then following Chapter 4 for operation.*
- 8. Make sure the truck engine idle, and then Accelerator Switch button can be PULL OUT to make PTO start working.*
- 9. When dump body start for discharging working, release the accelerator plate when last level hydraulic cylinder extend, then engine rotation speed slowdown, which can reduce the dump body lifting of inertia. When dump body to maximum lifting angle, stop the gear pump to avoid any emergency.*

Chapter 6 Troubleshooting

Please kindly checking below possible troubleshooting, which just for your reference.

Malfunction	Possible Reason	Solution
Gear Pump broke down	<ol style="list-style-type: none"> 1. PTO on Working Position during driving, and make PTO idling long time 2. Hydraulic oil shortage, long time lifting 	<ol style="list-style-type: none"> 1. Make sure PTO on Driving Position 2. Add enough hydraulic oil
No-load body not lifting	<ol style="list-style-type: none"> 1. PTO on Driving Position 2. Hydraulic oil shortage 3. Gear pump broke down and not hydraulic oil supply 4. Control Valve keeps ON 5. Hydraulic oil polluted 	<ol style="list-style-type: none"> 1. Check the gear and make PTO on Working Position 2. Add enough hydraulic oil 3. Repair or replace new gear pump 4. Control Device air shortage, add enough air and check the seals. Replace new valve if necessary 5. Cleaning all hydraulic system parts and change new hydraulic oil
Full-load body not lifting	<ol style="list-style-type: none"> 1. PTO on Driving Position 2. Dump truck over loading 3. Lifting working process on rough road 	<ol style="list-style-type: none"> 1. Check the gear and make PTO on Working Position 2. Use the truck with rated loading weight 3. Lifting working on flat road
Dump body can lift a little, not to the maximum lifting angle	<ol style="list-style-type: none"> 1. Air pressure not enough 2. Hydraulic oil shortage 	<ol style="list-style-type: none"> 1. Cleaning all hydraulic system parts and change new hydraulic oil 2. Add enough hydraulic oil
Dump body lifting to an angle then start falling down automatically	<ol style="list-style-type: none"> 1. Hydraulic system leakage 	<ol style="list-style-type: none"> 1. Carefully check all hydraulic parts, fasten the pipeline or change new parts to solve leakage problem
There is a noise during lifting process	<ol style="list-style-type: none"> 1. Dump truck over loading 2. Lifting working process on rough road 	<ol style="list-style-type: none"> 1. Use the truck with rated loading weight 2. Lifting working on flat road